

Towing truck 3.0 ton

BT movit

T-series

TSE300



Towing truck

Truck specifications					TSE300
Identification	1.1	Manufacturer			BT
	1.2	Model			TSE300
	1.3	Drive			Electric
	1.4	Operator type			Stand on
	1.5	Load capacity/rated load	Q	kg	3000
	1.7	Rated drawbar pull	F	N	1320
	1.9	Wheelbase	y	mm	1319
Weight	2.1	Service weight without battery		kg	1206 ¹⁾
	2.3	Axle load, without load, drive/support arm wheels		kg	1043/734
Wheels	3.1	Drive/support arm wheels			Vulkollan
	3.2	Wheel size, front		mm	Ø 250x100
	3.3	Wheel size, rear		mm	Ø 150x75
Dimensions	4.2.1	Overall height	h_{15}	mm	1284
	4.8	Stand height	h_7	mm	130
	4.12	Coupling height towing pin towing ball	h_{10}	mm	188/283/378/473
			h_{10}	mm	298/393/488/583
	4.19	Overall length	l_1	mm	1571
	4.21	Overall width	b_1/b_2	mm	790/799
	4.26	Distance between support arms	b_4	mm	613
	4.32	Ground clearance, centre of wheelbase	m_1/m_2	mm	63/71
	4.35	Turning radius	W_a	mm	1508
4.44	Clear width driver compartment entrance	l_{24}	mm	450	
Performance data	5.1	Travel speed, with/without load		km/h	9,0/12,0
	5.7	Gradeability, with/without load		%	6/13
	5.10	Service brake			1 stage electromagnetic
Electric motor	6.1	Drive motor rating S2 60 min		kW	2,8
	6.4	Battery voltage, nominal capacity K_5		V/Ah	24/465-620
	6.5	Battery weight, min./max.		kg	338/501
	6.6	Energy consumption acc to VDI cycle ²⁾		kWh/h	
Other	8.1	Type of drive control			BT Powerdrive
	8.4	Sound level at the driver's ear according to EN 12 053			66

1) With small battery, add 125 kg counterweight

2) Contact your supplier for information.

All data are based on table configuration. Other configurations may give other values.

Truck performance and dimensions are nominal and subject to tolerances.

Specifications are subject to change without notice.

Dimensional drawings

BT movit

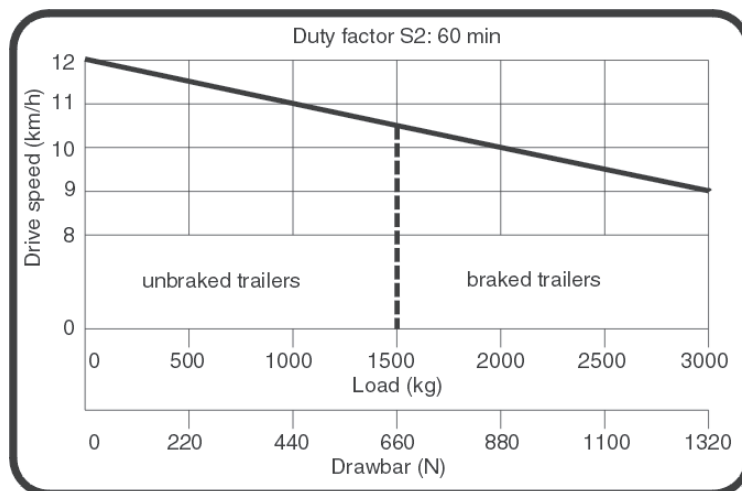
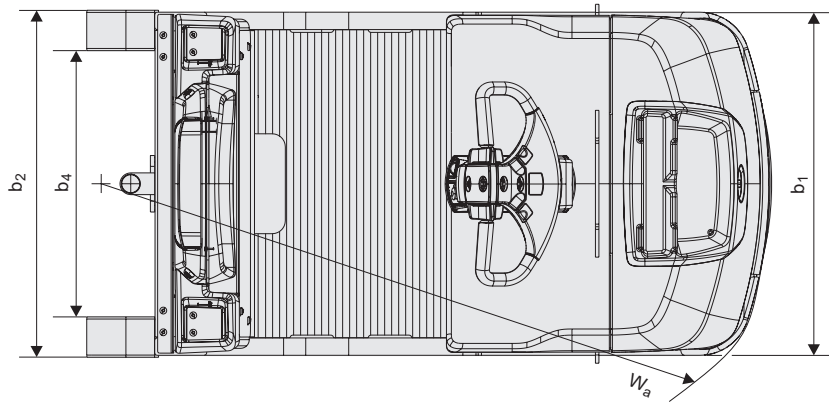
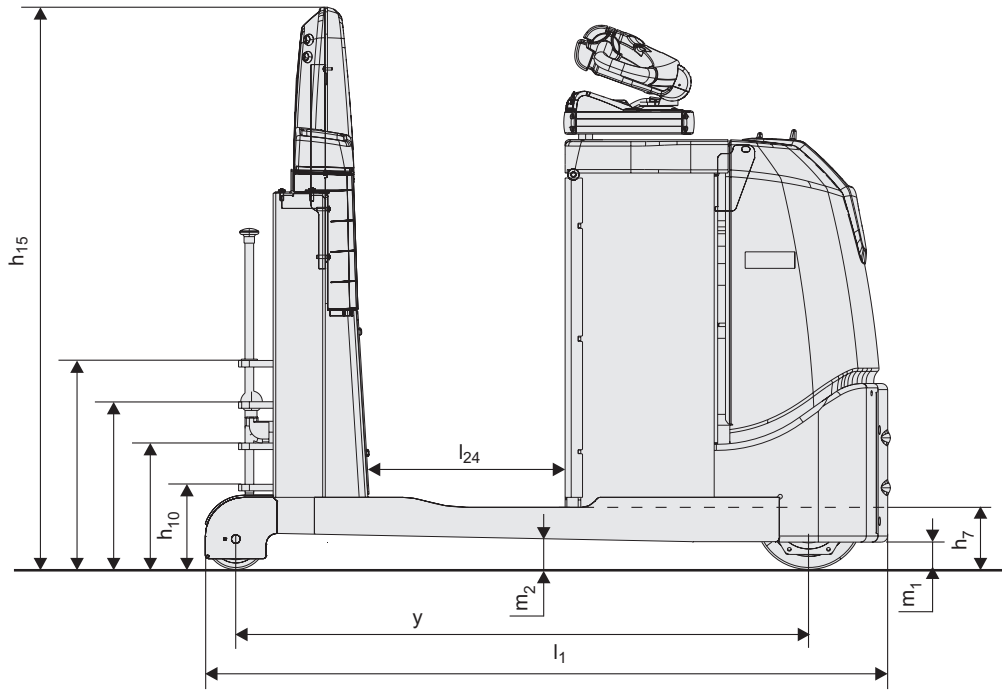

Truck features:

- High performance models
- BT E-man steering concept
- Low step-in
- Variety of towing connections
- BT Powerdrive system
- Integrated shrink film holder
- Streamlined administration
 - E-bar concept (option)
- Frequency adapted suspension (option)